

Acoem Wireless Balancer

WIRELESS INNOVATION CONTINUES





50
years of
Innovation

A legacy of innovation

For over 50 years, Acoem has led the evolution of industrial monitoring and maintenance technologies. With a heritage spanning five generations, we've earned a reputation for delivering reliable, future-ready solutions that push the boundaries of what's possible.

Serving thousands of customers across diverse industries, Acoem has consistently transformed the landscape – from portable tools to wired systems, to industry-first wireless solutions, and now to AI-powered, self-sufficient sensors and gateways. entirely. And we're just getting started.

Pioneering the wireless revolution since 2013



Falcon

The world's first portable vibration analyser with wireless data collection capabilities.



Eagle

The world's first IoT-enabled vibration wireless sensor for real-time diagnostics



Accurex™ AI

The first embedded AI diagnostic engine for vibration analysis.



Acoem Wireless Balancer Revolutionising balancing safety & accessibility

For the first time in the industry, Acoem introduces a fully wireless, real-time balancing solution for synchronous dual plane applications.

The Acoem Wireless Balancer simplifies the process by eliminating cables while delivering accurate, synchronous balancing of rigid rotors – with precision up to 0.5° at 3000 RPM. Seamlessly integrated into Acoem's connected, app-driven ecosystem, it enhances safety, speeds up setup, and brings next-level efficiency to industrial maintenance.



The industry's first 2-plane synchronous wireless balancing solution



Maximum safety & comfort

- No cables – move freely and work safely.
- Perform balancing from up to 20 metres away.



Easy & guided setup

- GuideU™ step-by-step with 3D visuals throughout.
- 360° field view that eliminates setup and reading errors.



Compact & portable

- Weighs under 2 kg and fits in a compact case.
- Rechargeable battery powers up to 10 balancing jobs per charge.



Cost efficient & field ready

- Low total cost of ownership with no cable maintenance. (replacement, cleaning)



Unbalance – A leading cause of machine failure





Unbalance is one of the most common and damaging faults in rotating machinery. It leads to increased vibration, accelerated wear, reduced bearing life, and unplanned downtime – all of which impact productivity, safety, and operational costs.

Despite its critical importance, balancing has seen little true innovation for decades. Traditional systems remain complex, time-consuming, and often rely on outdated, cable-bound technology that limits mobility, increases risk, and requires expert handling. It was time for a change.

Acoem redefined the process – removing barriers, enhancing safety, and making accurate balancing accessible to more people, in more places, than ever before.

Traditional Wired Approach

Acoem Wireless Balancer

	Cable hazards	Risk of entanglement & accidents	0 Cable-related hazards
	Data acquisition	Sequential or delayed	6 Channels acquired synchronously
	Setup	Complex & Time-consuming	50% Faster setup and no human errors
	System weight	Heavy & difficult to move	<2 kg Compact hardware kit



Changing the rules of the game in machinery balancing

6-Channel wireless vibration testing

Acoem's advanced system enables comprehensive vibration analysis with two triaxial wireless sensors, ensuring precise diagnostics across multiple axes.

Dual-plane synchronous wireless balancing

Achieve superior machine balance with ACOEM WBS™ technology which synchronizes vibration and tachometer data in real time.

Control plane visualisation

Instantly see the impact of adjustments on the second plane, helping you make the best balancing decisions with greater accuracy.

360° Machine view

Rotate the machine as you see it, minimising alignment errors and ensuring a seamless balancing process.

GuideU™ – intuitive assistance

Acoem's intuitive GuideU™ 3D graphical interface provides clear visual guidance that helps minimise human error.

Smart balancing assistants

Optimise balancing with 1 or 2-plane selection, trial weight recommendations, automatic weight splitting, and more for faster, more efficient corrections.

All-in-one ecosystem

Seamlessly integrate with Acoem's shaft alignment apps, Bearing Defender, Machine Defender, and report storage within NEST Vision, providing a complete monitoring and maintenance solution.



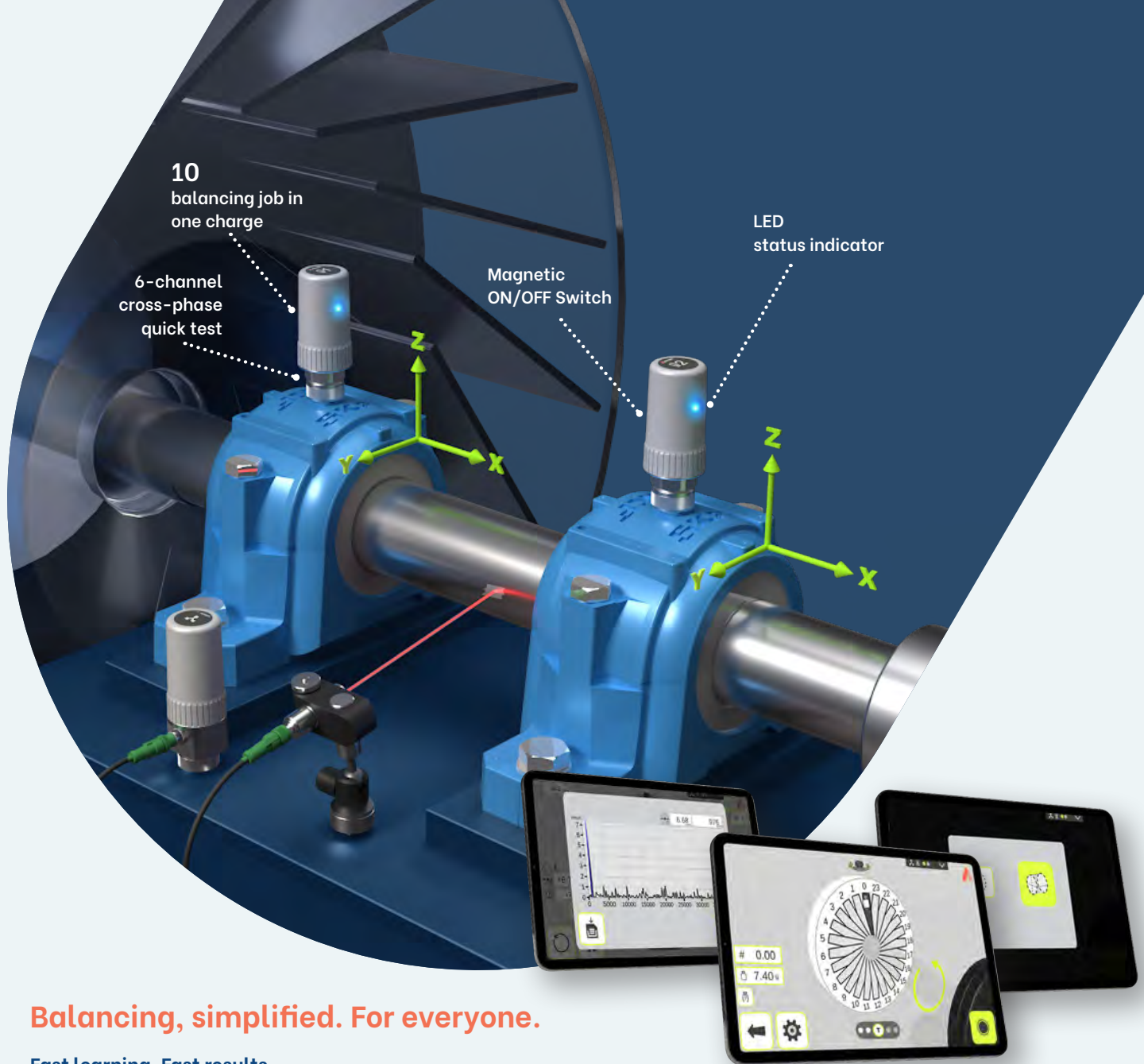

Balancing, simplified. For everyone.

Fast learning. Fast results.

- GuideU™ graphical guidance makes every step intuitive – even for first-time users.
- Automatic error avoidance for setup directions, angles & rotation.
- 360° machine visualisation ensures precise placement and complete field awareness.

Precision at every step

- Real-time 3D control plane display – see both planes and directions at once.
- Switch instantly between radial directions for clearer, faster balancing.
- Live ISO standard comparison for confident decision-making.

More sensors, more efficiency

- 6-direction simultaneous measurement – no more waiting, guessing, or retesting.
- One-click dual-plane sync drastically cuts down balancing time.

Rugged, reliable & industry-ready

- Built to handle the toughest environments with stable, interference-resistant performance.
- Compact but powerful – designed for field use, factory floors, and everything in between.

Low maintenance, low cost

- No cables = no recurring costs for cleaning, replacing, or untangling.
- A smarter, lighter, cost-effective alternative to bulky legacy systems.



Simplifying balancing at every step

Step 1

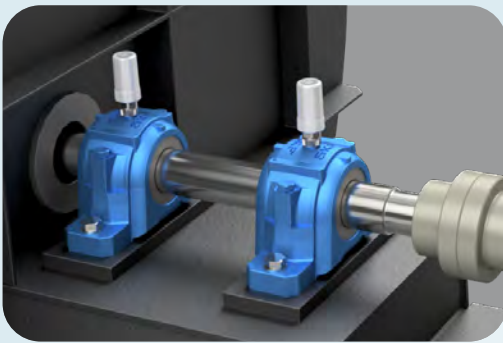

Wireless sensors & timekeeper setup

- Attach the two wireless accelerometers to the machine.
- Position the wireless laser tachometer for RPM detection.

Step 2



Data collection & synchronisation

- The Timekeeper synchronises real-time data from sensors and transmits it wirelessly to the user's device.
- Live feedback enables immediate adjustments, reducing machine downtime.

Step 3



Real-time guided balancing

- Acoem GuideU™ provide step-by-step graphical guidance for precision balancing.
- Smart weight placement recommendations optimise corrections, reducing the number of balancing runs.

Step 4

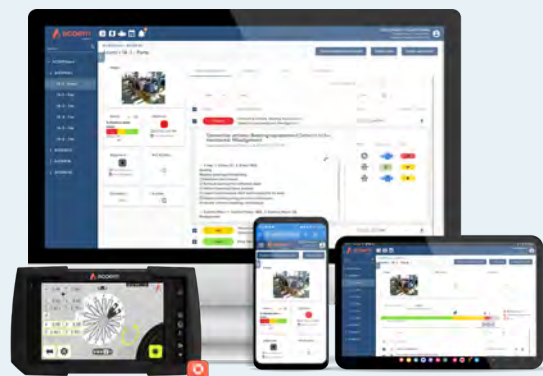

Analysis & report generation

- Instantly share customisable balancing reports and integrate results directly into the machine's maintenance history using Acoem NEST Vision.

Acoem:
Your partner in industrial reliability

At Acoem, we are committed to helping organisations and public authorities find the right balance between progress and preservation. We empower industries with smarter, data-driven reliability solutions to safeguard assets, optimise performance, and ensure operational excellence. Our AI-powered monitoring systems and expertise help organisations predict, prevent, and resolve reliability challenges with confidence.

With a global presence in 50 countries and dedicated reliability centres in strategic locations worldwide, we provide localised expertise and support to keep industries running efficiently.



Reliability centres

- **Australia**
- **Brazil**
- **Canada**
- **France**
- **Germany**
- **India**
- **Sweden**
- **Thailand**
- **USA**
- **UK**

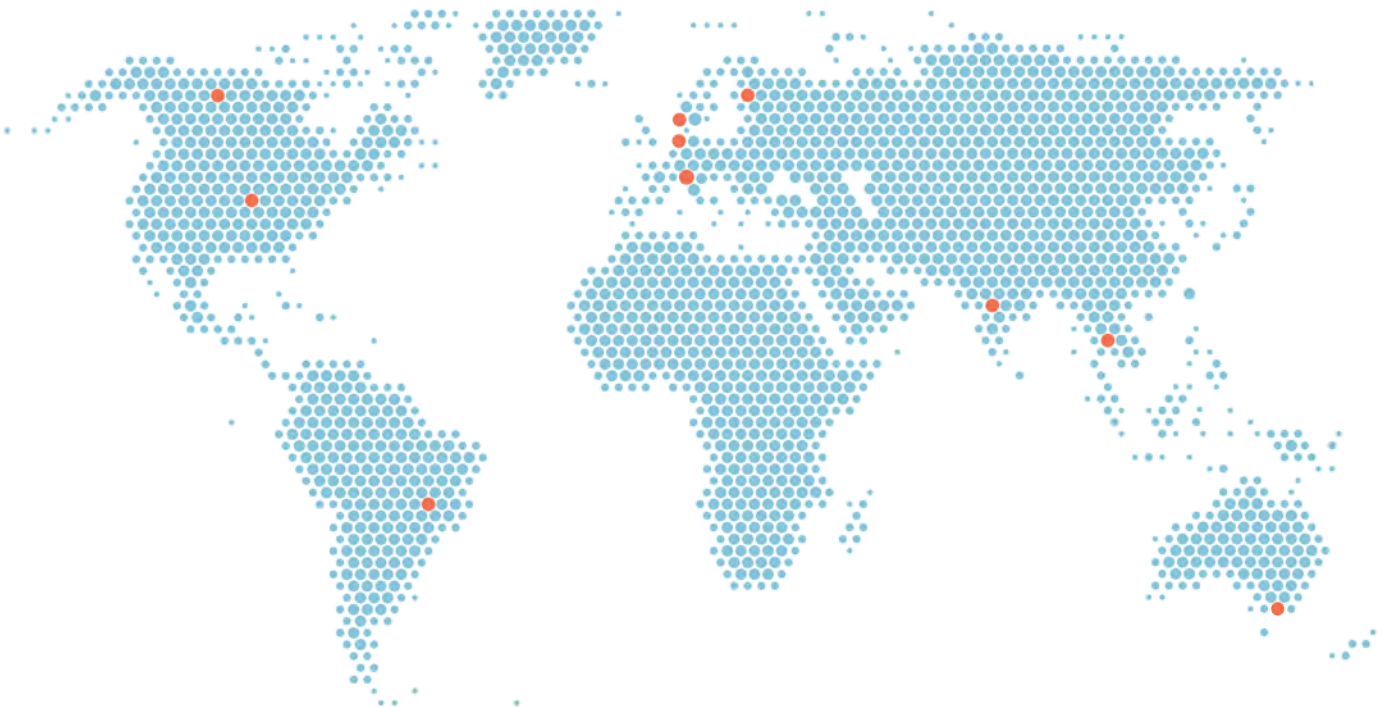

Fixturlaser South Africa (Pty)Ltd
70 Lessing Street, Rynfield, Benoni
Gerrit +27 84 875 0756
Steve +27 73 724 9692



acoem.com

